



Tel : +44 (0)1798 877000
Fax : +44 (0)1798 872479
e-mail : hvsales@spellmanhv.co.uk

Broomers Park, Broomers Hill Lane
Pulborough, W. Sussex, RH20 2RY

High Voltage Power Supply MPS 1kV to 20kV SERIES

SAFETY AND INSTALLATION INSTRUCTIONS

Document number: 80389-4

Issue	3	4	5
Date	07/09/06	25/01/07	20/06/07
Issuing Authority	5009	5106	5214
Checked			
Approved			

Spellman High Voltage Electronics Limited
Company Confidential

This document must not be copied or distributed without express permission from Spellman High Voltage Electronics Limited

CHANGE HISTORY

Section	Reason for Change	Issue
All	Original	1
1 4 5.5	/DCC option added and explanation of part numbers included. Table 2 added RS232 connection details added.	2
Front page 3 Table 1 5	Range now 1kV to 20kV Explanation of symbols added and subsequent sections renumbered. Signal ground added for 15kV and 20kV units. Mechanical outline of 15kV and 20kV added	3
5 Mech. Outlines	Mounting hole positions corrected	4
5 Mech. Outlines	Mounting hole positions corrected	5

SAFETY



DANGER HIGH VOLTAGE RISK OF ELECTROCUTION

Observe extreme caution when working with this equipment

- ▲ High voltage power supplies must always be connected to a protective earth
- ▲ Do not touch connections unless equipment is turned off and the capacitance of both the load and power supply are grounded
- ▲ Allow adequate time for discharge of internal capacitance of the power supply
- ▲ Do not ground yourself or work under wet or damp conditions

Servicing Safety

- ▲ When maintenance of equipment fitted with this power supply requires removing the equipment cover with the power on, this should only be done by qualified personnel aware of the hazards
- ▲ This power supply has no user serviceable parts. Return to supplier for servicing

1 Unit Description

The MPS series of high voltage dc-dc converters is a range of units designed to produce a high quality dc output for a very wide range of instrumentation and analytical applications. The combination of linear and switch mode power conversion techniques provide low noise and high efficiency. The unit also offers excellent ripple and stability specification. The standard unit incorporates the ability to pre set the output or control it over the full output range with good linearity performance. A differential input is also available to eliminate system noise problems.

The units are designed for operation from a 24V dc input and will supply up to 10W of output power. The HV output is via a 1m long un-terminated URM76 LSF screened cable. The signal and power inputs and outputs are via a 15 way male 'D' connector but the pinout of this connector varies according to the model type.

Three factory configured options are available :-

/VCC : Voltage and Current Control option, allowing current control of the unit.

/HS : High Stability option offering a temperature coefficient of $<10\text{ppm } ^\circ\text{C}^{-1}$

/DCC: Digital Control Card option with digital control and monitoring (factory configured to either RS232 or RS485 interface standards, 9600 baud).

The part number for the unit describes its main characteristics :-

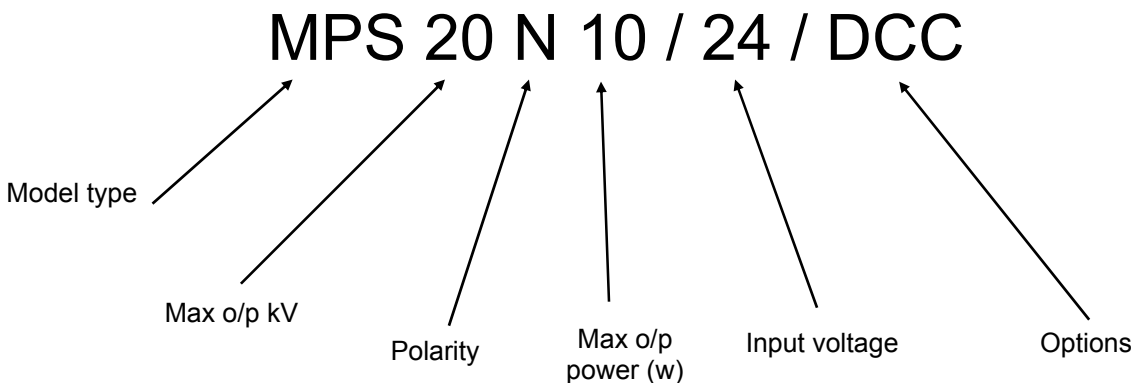

2. Safety

The HV output of the unit is hazardous and the conditions of this manual must be complied with to maintain safety. The unit is contained in an earthed case with a screened HV output cable and the HV output cable must be terminated safely before the unit is operated. This unit must be sourced with a double insulated 24 V dc supply.

The unit shall be properly bonded to the main protective earthing termination in the end product.

The unit has been evaluated for use in a Pollution Degree 2, Installation Category II environment.

Consideration should be given to conducting the following tests with the unit installed in the end product:

- a. Dielectric Voltage Withstand Test, between live parts of the unit and the end product chassis.
- b. Permissible Limits Tests with the unit installed in the end product.
- c. Temperatures on power electronic components, transformer windings and accessible surfaces.

The case performs the function of heat sink and can exceed 60°C, therefore accessibility should be prevented during operation.

3. Explanation of Symbols



This symbol means Caution, risk of danger and the installation manual should be consulted before proceeding.



This symbol means Caution, risk of electric shock.



This symbol indicates the Functional Earth (ground) terminal.



This symbol means Caution, hot surface

4. Applicable standards

The unit is CE marked and the standard units are UL listed.

The Standards applied are:

BS EN61010-1: 2001 and UL61010A-1
Safety requirements for electrical equipment for measurement, control and laboratory use.

5. Installation

The connector details on the standard unit, VCC and HS versions are shown in table 1 overleaf. The DCC version is shown in table 2. See section 5 for more information on various connection methodologies.

Table 1 : Non /DCC units connector pin-out

Pin	Signal Name	Parameters
1	Power/Signal Ground	Power Ground (also used as signal ground on 1kV to 10kV units.
2	+24Vdc Input	+24Vdc @ 1 amp maximum
3	Voltage Monitor Output	0 to 10 Vdc equals 0 to 100% of rated output, Zout = 10k Ω
4	Local Programming Potentiometer Wiper Output	Potentiometer connected to +10Vdc reference and ground, 0 to 10Vdc adjustable wiper output provided
5	Voltage Program Input	0 to 10 Vdc equals 0 to 100% of rated output, Zin = 10M Ω
6	Voltage Program Differential Amplifier Output	0 to 10 Vdc equals 0 to 100% of rated output, Zout = 10k Ω
7	Voltage Program Differential Amplifier Input – Positive	0 to 10 Vdc differential between pin 7 and pin 9 equals 0 to 100% of rated output, diode clamped to ground, Zin = 38k Ω
8	Current Monitor Output	0 to 10 Vdc equals 0 to 100% of rated output, Zout = 10k Ω
9	Voltage Program Differential Amplifier Input - Negative	0 to 10 Vdc differential between pin 7 and pin 9 equals 0 to 100% of rated output, diode clamped to ground, Zin = 38k Ω
10	Internal Connection	Do Not Use
11	Current Program Input	Standard: Internally connected to provide 110% fixed current limit VCC Option: 0 to 10 Vdc equals 0 to 100% of rated output, Zin = 1M Ω
12	Enable Input	Low = Enable. TTL, CMOS, open collector compliant
13	Internal Connection	Do Not Use
14	Vref (/HS unit only)	+10V ultra high stability reference output. On standard units the reference voltage is available on pin 4.
15	Internal Connection/signal ground	Do Not Use on 1kV to 10kV units. Used as signal ground on 15kV to 20kV units.

Table 2 : /DCC units connector pin-out

Pin	Signal Name	Parameters
1	Power/Signal Ground	Ground
2	+24Vdc Input	+24Vdc @ 1A maximum
3	Voltage Monitor Output	Not used
4	Local Programming Potentiometer Wiper Output	Potentiometer connected to +10Vdc reference and ground, 0 to 10Vdc adjustable wiper output provided
5	Internal Connection	Do not connect
6	Voltage Program Differential Amplifier Output	Not used
7	Voltage Program Differential Amplifier Input – Positive	Not used
8	Current monitor output	Not used
9	Voltage Program Differential Amplifier Input - Negative	Not used
10	Internal Connection	Do not connect
11	Current Program Input	Not used
12	Enable Input	Low = Enable. TTL, CMOS, open collector compliant
13	Internal Connection	Do not connect
14	TxD	Transmit data (output) wrt pin 1
15	RxD	Receive data (input) wrt pin 1

The unit is contained in an earthed case, which should be securely mounted and the HV output cable must be terminated safely.

Fixings

M3 x 0.5 blind inserts, maximum thread depth 5mm.

Mechanical Outline 1kV to 10kV units.

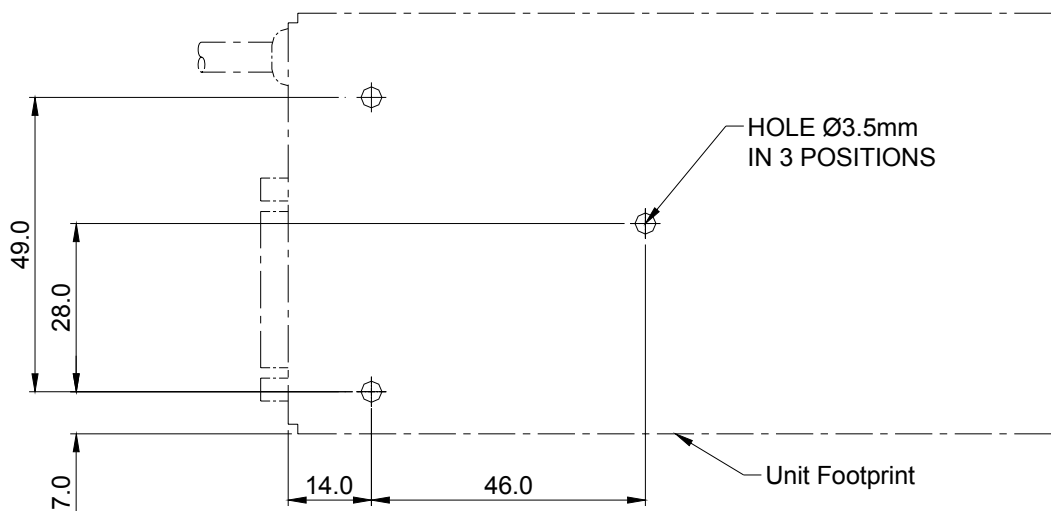
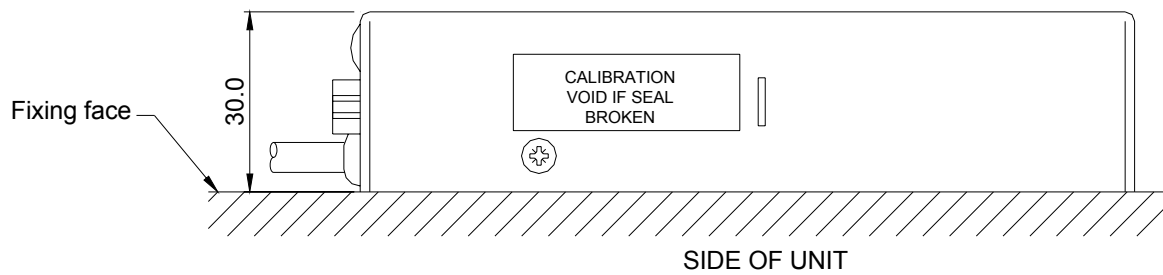
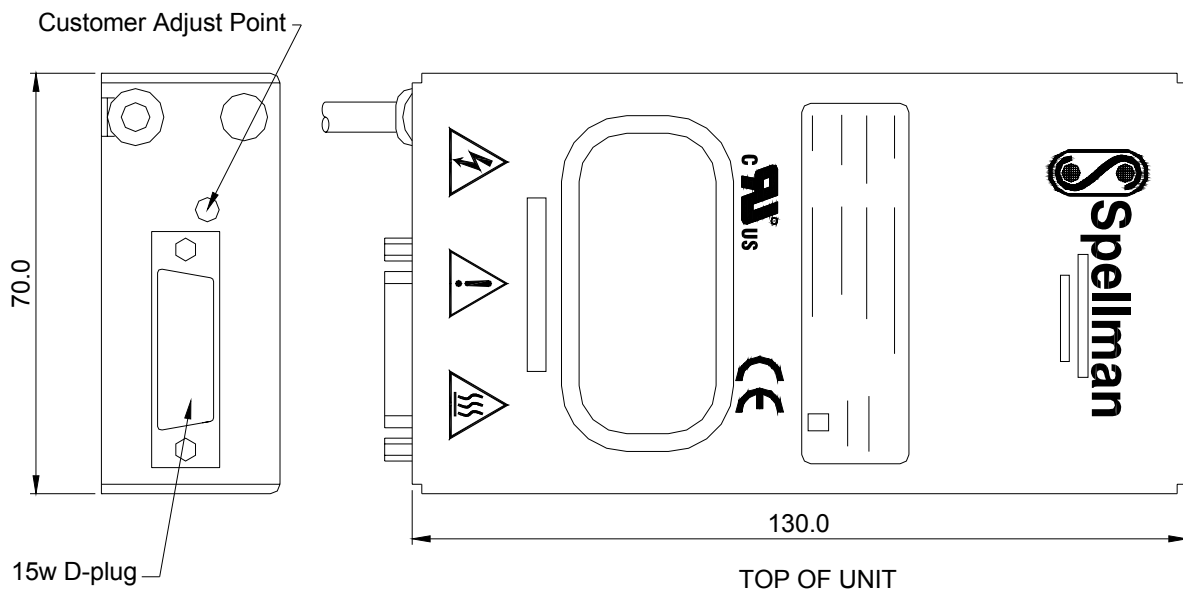

70383

MOUNTING HOLE TEMPLATE
(NOTE - Max thread depth into unit is 5mm)

Mechanical Outline 15kV to 20kV units.

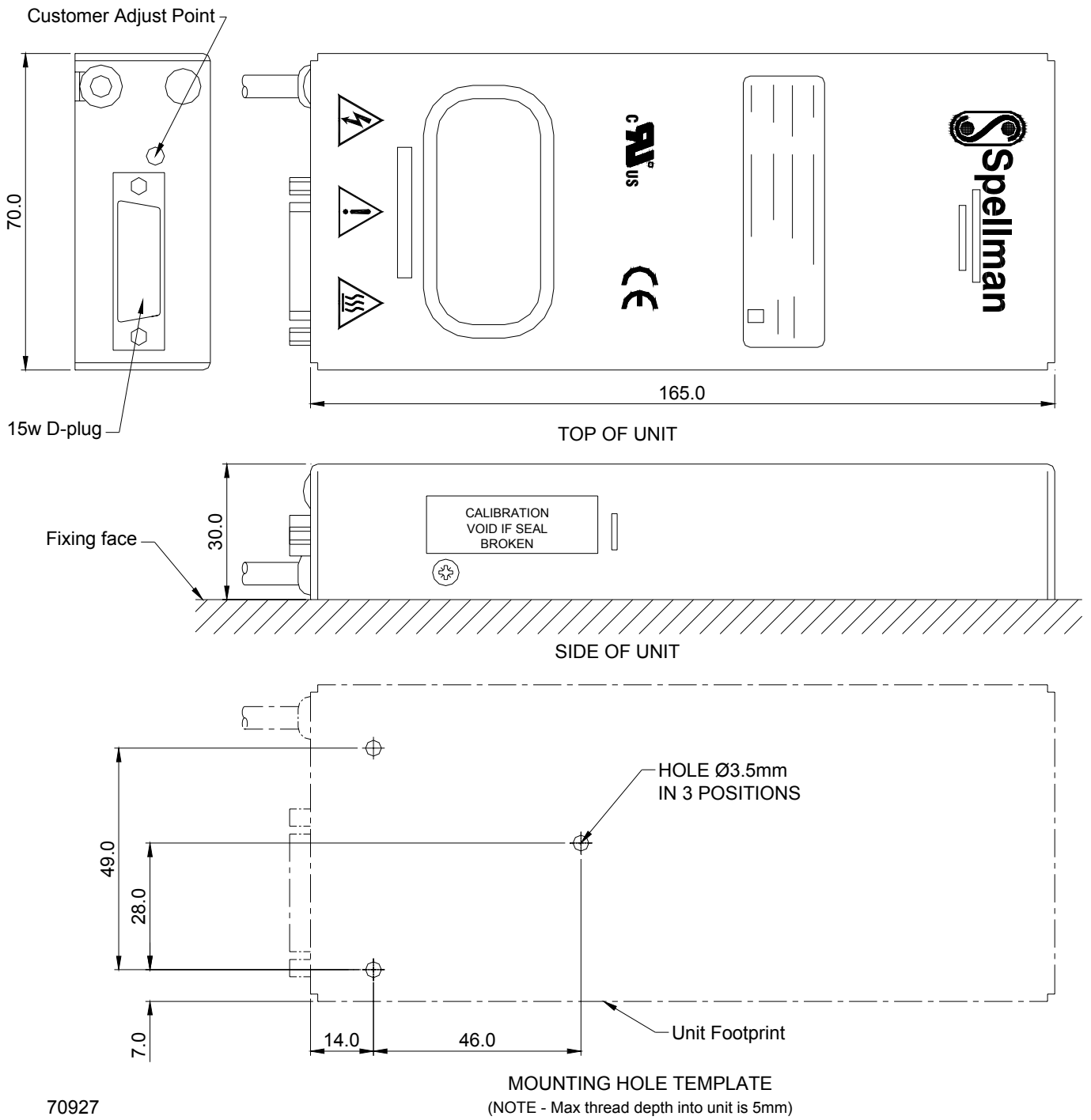

6. Connection Details

6.1. Remote DAC control

The differential input allows the voltage programming circuit to be remote from the power supply. It prevents voltage drops in the ground connection from affecting the programming signal. However, if there are voltage drops in the ground connection, the DAC should be provided with its own reference.

24V Power input on Pin 2.

Ground on Pin 1.

0 to 10V voltage control signal to Pin 7.

Signal ground reference for 0 to 10V control signal. (Must be connected to signal ground for 0 to 10V voltage control)

Link Pin 5 to Pin 6.

Connect Enable Pin 12 to ground to enable HV output.

Voltage monitor output is on Pin 3.

Current monitor output is on pin 8.

Note : 15kV and 20kV units have an additional signal ground available on pin 15 this should be used as the ground for the VMON and IMON signals to achieve the best performance.

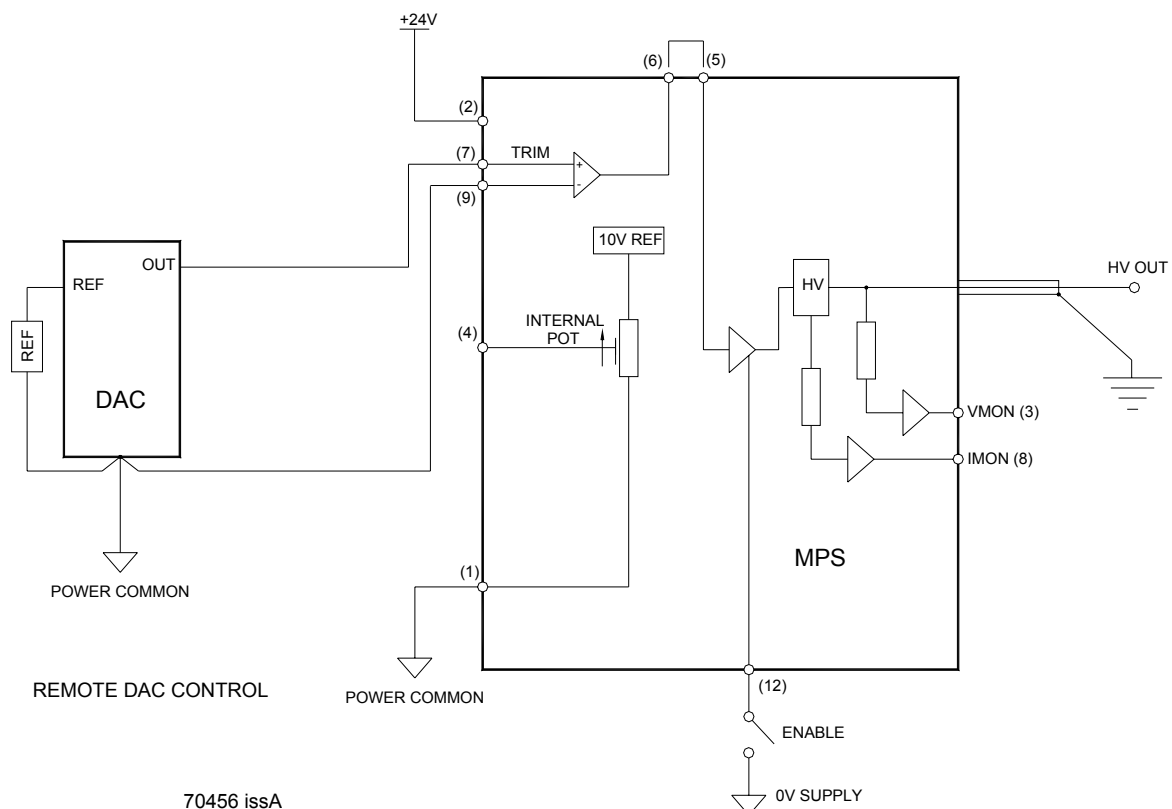

6.2 Local DAC control

The unit has an internal potentiometer near the D type input connector, which is connected to the +10V reference. The output from the wiper of the internal pot may be used as a reference for the DAC. Set the internal pot to maximum to make the +10V reference available to external circuits.

It is not necessary to use the differential input when the voltage control circuit is close to the power supply, however it is important to connect all grounds at Pin 1 of the PSU to prevent voltage drops in the ground circuit from affecting the programming signal. Take care to avoid ground loops.

24V Power input on Pin 2.

Ground on Pin 1.

DAC output to Pin 5.

Connect Pin 4 to the DAC reference input.

Set the internal pot to maximum.

Connect Enable Pin 12 to ground to enable HV output.

Voltage monitor output is on Pin 3.

Current monitor output is on pin 8.

Note : 15kV and 20kV units have an additional signal ground available on pin 15. This should be used as the ground for the VMON and IMON signals and the reference ground for the DAC to achieve the best performance.

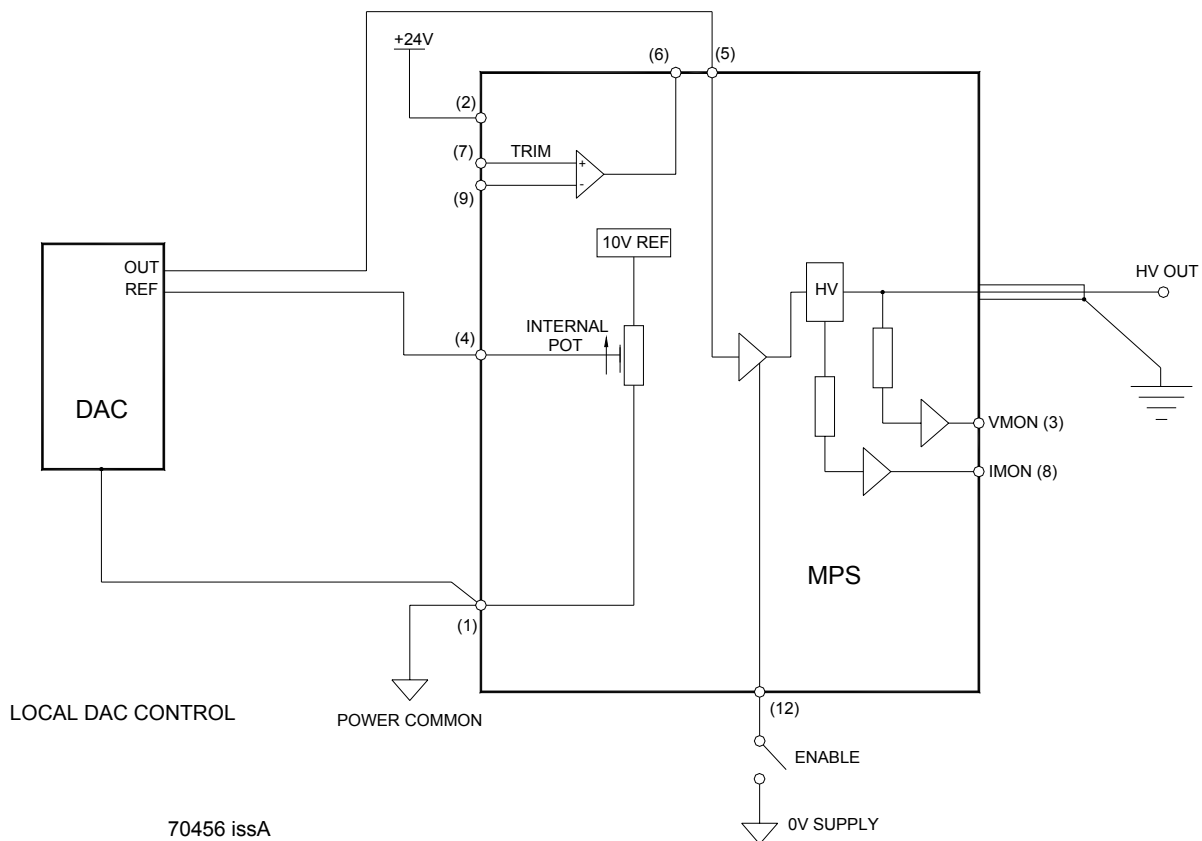

6.3 Internal potentiometer control

The unit has an internal potentiometer near the D type input connector, which is connected to the +10V reference. The unit may be controlled by the internal potentiometer as follows: -

24V Power input on Pin 2.

Ground on Pin 1.

Link Pin 4 to Pin 5.

Connect Enable Pin 12 to ground to enable HV output.

Voltage monitor output is on Pin 3.

Current monitor output is on Pin 8.

Note : 15kV and 20kV units have an additional signal ground available on pin 15 this should be used as the ground for the VMON and IMON signals to achieve the best performance.

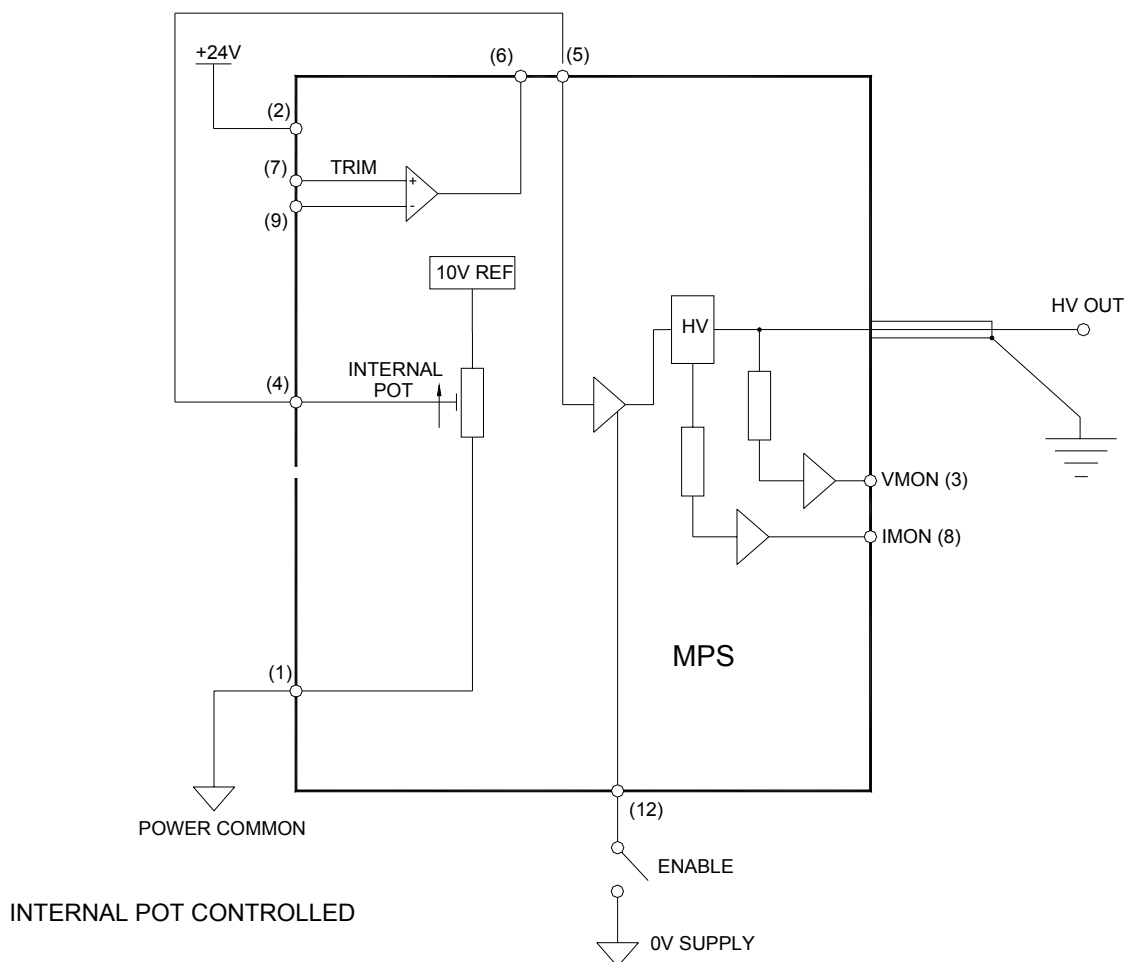

6.4 External potentiometer control

The unit has an internal potentiometer near the D type input connector, which is connected to the +10V reference. An external potentiometer may be connected to the wiper of the internal pot. Set the internal pot to give the desired maximum output voltage and control the unit using the external potentiometer.

The unit may be controlled by an external potentiometer as follows: -

24V Power input on Pin 2.

Ground on Pin 1.

Link Pin 4 to external pot CW.

Link Pin 1 to external pot CCW.

Link Pin 5 to external pot wiper.

Connect Enable Pin 12 to ground to enable HV output.

Voltage monitor output is on Pin 3.

Current monitor output is on Pin 8.

Note : 15kV and 20kV units have an additional signal ground available on pin 15. This should be used as the ground for the VMON and IMON signals and the ground for the external potentiometer to achieve the best performance.

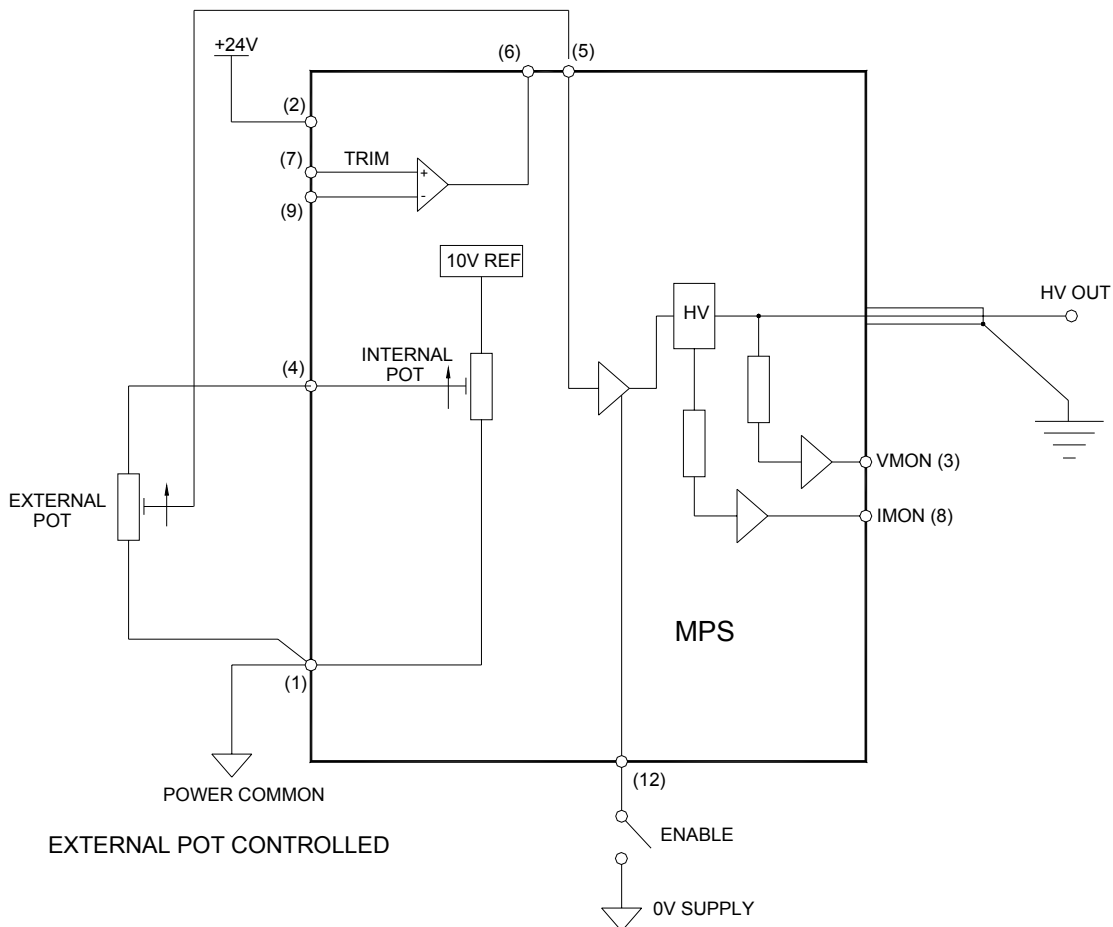

6.5 RS232 control (/DCC) versions only

The unit has RS232 (or RS485) communication facilities available via pins 14 and 15 of the 15 way 'D' connector. For the protocol used refer to unit specification, the 'standard' protocol can be provided on request.

The unit may be controlled digitally as follows: -

24V Power input on Pin 2.

Ground on Pin 1.

RS232 transmit on pin 14 – connect to Rx pin on PC

RS232 receive on pin 15 – connect to Tx pin on PC

Connect Enable Pin 12 to ground to enable HV output. This is independent of the firmware/communications interface and can be used to shutdown the HV output.

If required there are analog monitor outputs available :-

Voltage monitor output is on Pin 3.

Current monitor output is on Pin 8.

However these are intended mainly for indication only, the primary control and monitoring function should be performed via the digital interface.

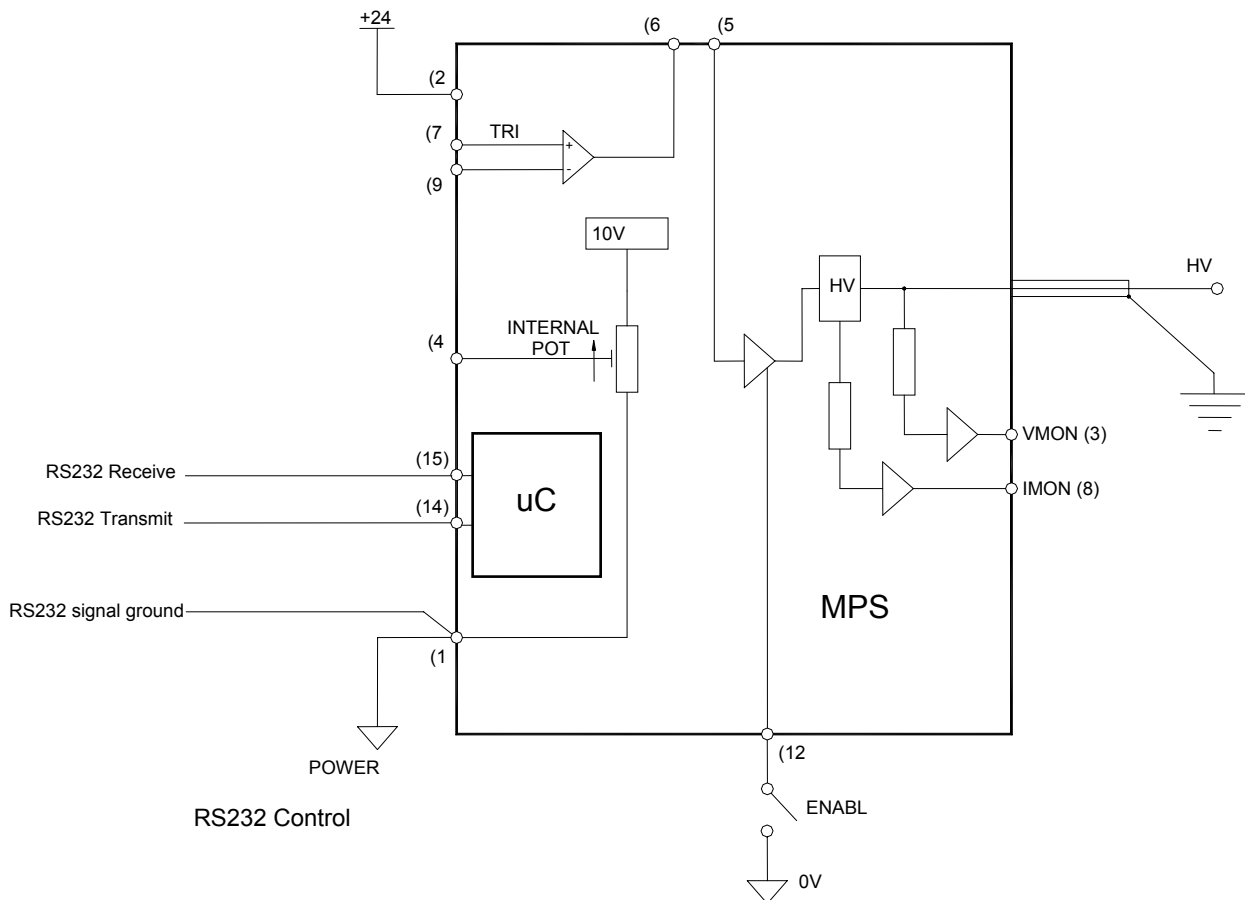

Note: Failure to comply with the above could compromise the safe operation of the unit and invalidate the warranty.